

## DRG-AR-AC AC Input, Field Configurable Limit Alarm

Instruction Sheet M2396/0796

### DESCRIPTION

The DRG-AR-AC is a DIN rail mount, AC voltage or current input limit alarm with dual setpoints and two contact closure outputs. The field configurable input and alarm functions offer flexible setpoint capability. Input voltage spans from 100mV to 200VAC and input current spans from 10mA to 100mAAC can be field configured. For current input spans of 1 to 5 Amps a 0.1W (5W) shunt resistor should be used.

The DRG-AR-AC is configurable as a single or dual setpoint alarm, with HI or LO trips and failsafe or non-failsafe operation. Also included are adjustable deadbands (0.25 to 5% of full scale input) for each setpoint and a flexible DC power supply which accepts any voltage between 9 and 30VDC.

### DIAGNOSTIC LEDES

The DRG-AR-AC is equipped with three front panel LEDs. The first is a dual function LED labeled INPUT. This green LED indicates DC power and input signal status. Active DC power is indicated by an illuminated LED. If this LED is off, check DC power and wiring connection. If the input signal is more than 110% of the full scale range, the LED will flash at 8 Hz.

Two red LEDs indicate the relay state for each setpoint. An illuminated red LED indicates the tripped condition.

### OUTPUT

The DRG-AR-AC is equipped with two SPDT (form C) relays, rated at 120VAC or 28VDC at 5 amperes. Each of these relays is independently controlled by the field configurable setpoint and deadband.

### OPERATION

The field configurable DRG-AR-AC limit alarm setpoints can be configured for HI or LO, failsafe or non-failsafe operation. Each of the setpoints have a respective HI or LO deadband. In a tripped condition, the setpoint is exceeded and the appropriate red LED will illuminate. The trip will reset only when the process falls below the HI deadband or rises above the low deadband (see Figure 1). For proper deadband operation, the HI setpoint must always be set above the LO setpoint.

In failsafe operation, the relay is energized when the process is below the HI setpoint or above the LO setpoint (opposite for non-failsafe). In the failsafe mode, a power failure results in an alarm state output.

### DYNAMIC DEADBAND

LSI circuitry in the DRG-AR-AC prevents false trips by repeatedly sampling the input. The input must re

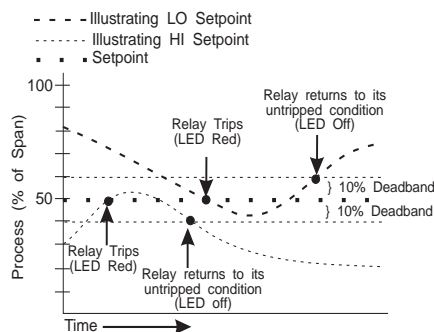

Figure 1: Limit alarm operation and effect of deadband(s).

main beyond the setpoint for 100 milliseconds, uninterrupted, to qualify as a valid trip condition. Likewise, the input must fall outside the deadband

and remain there for 100 milliseconds to return the alarm to an untripped condition. This effectively results in a “dynamic deadband” —based on time— in addition to the normal deadband.

### CONFIGURATION

Unless otherwise specified, the factory presets the Model DRG-AR-AC as follows:

Input:	Voltage
Range:	0-500mVAC
Output:	Dual, SPDT
Trip:	A:HI, B:LO
Failsafe:	No
Deadband:	A, B: 0.25%

The DC power input accepts any DC source between 9 and 30V, typically a 12V or 24VDC source is used.

For other I/O ranges, refer to Table 1 and Figure 4 to reconfigure switches SW2, SW3 and SW4 for the desired input type, range and function.

**WARNING:** Do not attempt to change any switch settings with power applied. Severe damage will result!

1. With DC power off, position input switch "SW1-9,10" for voltage or current.

2. Set position 1 through position 8 of input range switch "SW1" for the desired input range (see Table 1).

3. Set position 1 and 2 of function switch "SW2" to ON for a HI trip setpoint or OFF for a LO trip (see Figure 4).

4. Set position 4 of function switch "SW2" to ON for non-failsafe operation or OFF for failsafe operation (e.g. alarm trips when power fails).



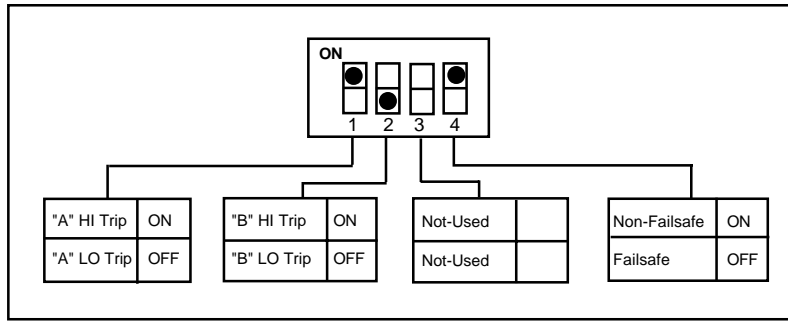

Figure 4: DRG-AR-AC Function Selection Switch-Settings (SW2) Factory Default Settings

## RELAY PROTECTION AND EMI SUPPRESSION

When switching inductive loads, maximum relay life and transient EMI suppression is achieved using external protection (see Figures 2 and 3). Place all protection devices directly across the load and minimize all lead lengths. For AC inductive loads, place a properly-rated MOV across the load in parallel with a series RC snubber. Use a

0.01 to 0.1 $\mu$ F pulse film capacitor (foil polypropylene recommended) of sufficient voltage, and a 47 $\Omega$ , 1/2W carbon resistor. For DC inductive loads, place a diode across the load (PRV > DC supply, 1N4006 recommended) with (+) to cathode and (-) to anode (the RC snubber is an optional enhancement).

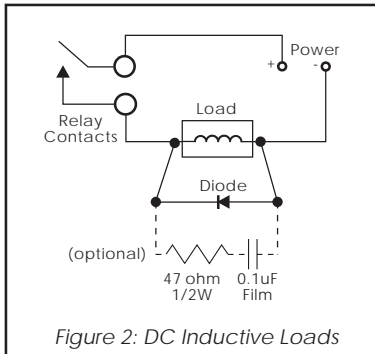

Figure 2: DC Inductive Loads

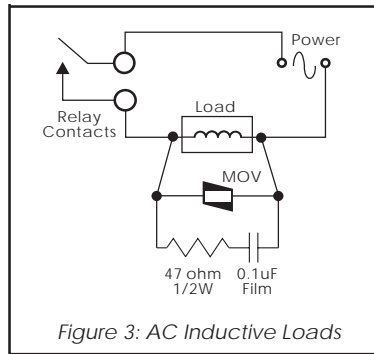

Figure 3: AC Inductive Loads

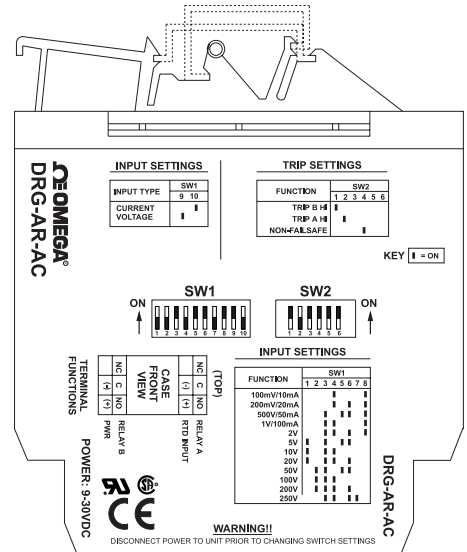

Figure 5: DRG-AR-AC Factory Calibration; 0-500mV, A-HI/B-LO, Non-Failsafe

**Warning:** Do not attempt to change any switch settings with power applied. Severe damage may occur!

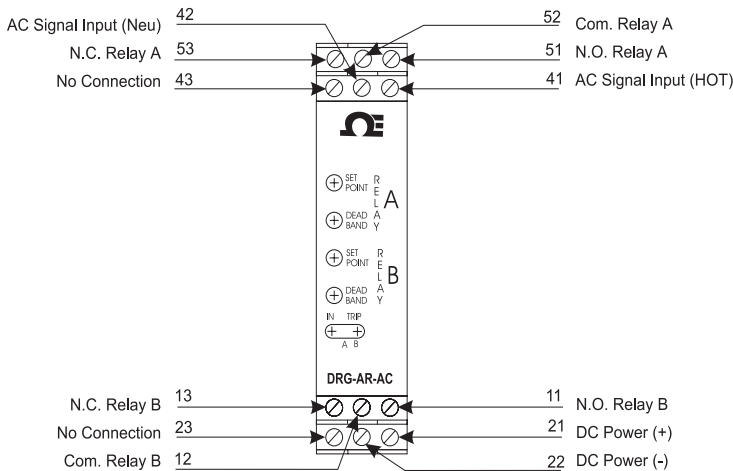

Figure 6: Wiring Diagram for DRG-AR-AC

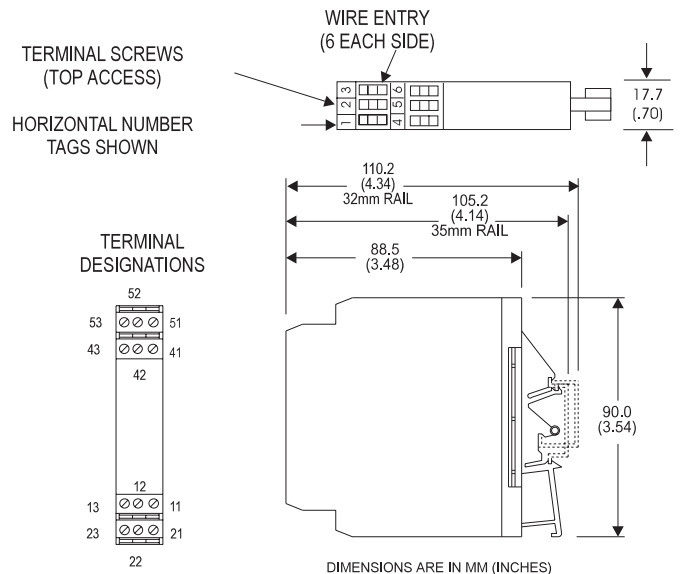

Figure 7: Mechanical Dimensions for DRG-AR-AC

## SPECIFICATIONS

### Inputs

#### Voltage Input

Range: 100mV to 200VAC

Impedance: >100KΩ

Overvoltage: 300VAC, max.

#### Current Input

Range: 10mA to 100mAAC

Impedance: 20Ω, typical

Overcurrent: 200mAAC, max.

Overvoltage: 60V peak (protected by self resetting fuse)

Frequency Range: 40 to 400Hz

Common Mode (Input to Ground):

1800VDC, max.

### LED Indicators

Input Range (Green)

>110% input: 8Hz flash

Setpoint (Red)

Tripped: Solid red

Safe: Off

### Limit Differentials (Deadbands)

>50mV/5mA: 0.25% to 5% of span

<50mV/5mA: 1% to 5% of span

### Response Time

Dynamic Deadband: Relay status will change when proper setpoint/process condition exists for 100msec.

Normal Mode (analog filtering):

<250mSec, (10-90%)

### Setpoints

Effectivity: Setpoints are adjustable over 100% of the selected input span

Repeatability (constant temp.):

0.2% of full scale

### Stability

Temperature: ±0.025% of full scale/°C, max.

### Common Mode Rejection

DC to 60Hz: 120dB

### Isolation

1800VDC between contacts, input and power

### EMC Compliance (CE Mark)

Emissions: EN50081-1

Immunity: EN500-82-2

Safety: EN50178

### Humidity (Non-Condensing)

Operating: 15 to 95% (@45°C)

Soak: 90% for 24hours (@65°C)

### Temperature Range

Operating: 0 to 55°C

(32 to 131°F)

Storage: -25 to 70°C

(-13 to 158°F)

### Power

Consumption: 1.5W typical, 2.5W max.

Supply Range: 9 to 30VDC, inverter isolated

In-rush Current: 300mA, max.

### Relay Contacts

2 SPDT (2 form C) Relays

1 Relay per setpoint

Current Rating (resistive)

120VAC: 5A

240VAC: 2A

28VDC: 5A

Material: Silver-Cadmium Oxide

Electrical Life: 10<sup>5</sup> operations at rated load

Note: External relay contact

protection is required for use with inductive loads (see Figures 2 & 3).

Mechanical Life: 10<sup>7</sup> operations

### Wire Terminations

Screw terminals for 12-22 AWG

### Agency Approvals

CSA certified per standard C22.2, N o . 0-M91 and 142-M1987 (File No. LR42272). UL recognized per standard UL508 (File No.E99775). CE Compliance per EMC directive 89/336/EEC and low voltage 73/23/EEC.

### Mounting

32mm and 35mm DIN rail

### PIN CONNECTIONS

11 N.O. Relay B

12 Com. Relay B

13 N.C. Relay B

21 DC Power (+)

22 DC Power (-)

23 No Connection

41 AC Signal Input (HOT)

42 AC Signal Input (Neu)

43 No Connection

51 N.O. Relay A

52 Com. Relay A

53 N.C. Relay A



OMEGAnet <sup>SM</sup> On-Line Service <a href="http://www.omega.com">http://www.omega.com</a>	Internet e-mail <a href="mailto:info@omega.com">info@omega.com</a>
---	---

#### Service North America:

USA: One Omega Drive, Box 4047  
Stamford, CT 06907-0047  
Telephone: (203) 359-1660 Fax: (203) 359-7700  
e-mail: [info@omega.com](mailto:info@omega.com)

Canada: 976 Bergar  
Laval (Quebec) H7L 5A1  
Telephone: (514) 856-6928 Fax: (514) 856-6886  
e-mail: [canada@omega.com](mailto:canada@omega.com)

#### For immediate technical service or application assistance:

USA and Canada: Sales Service: 1-800-826-6342 / 1-800-TC-OMEGA<sup>SM</sup>  
Customer Service: 1-800-622-2378 / 1-800-622-BEST<sup>SM</sup>  
Engineering Service: 1-800-872-9436 / 1-800-USA-WHEN<sup>SM</sup>  
TELEX: 996404 EASYLINK: 62968934 CABLE: OMEGA

Mexico and Latin America: Tel: (95) 800-TC-OMEGA<sup>SM</sup> Fax: (95) 203-359-7807  
En Espanol: (203) 359-1660 ext. 2203 e-mail: [espanol@omega.com](mailto:espanol@omega.com)

#### Service Europe:

Benelux: Postbus 8034, 1180 LA Amstelveen, The Netherlands  
Tel: (31) 20 6418405 Fax: (31) 20 6434643  
Toll Free in Benelux: 06 0993344  
e-mail: [nl@omega.com](mailto:nl@omega.com)

Czech Republic: Ostravska 767, 733 01 Karvina  
Tel: 42 (69) 6311899 Fax: 42 (69) 6311114  
e-mail: [czech@omega.com](mailto:czech@omega.com)

France: 9, rue Denis Papin, 78190 Trappes  
Tel: 33 0130-621-400 Fax: 33 0130-699-120  
Toll Free in France: 05-4-06342  
e-mail: [france@omega.com](mailto:france@omega.com)

Germany/Austria: Daimlerstrasse 26, D-75392 Deckenpfronn, Germany  
Tel: 49 (07056) 3017 Fax: 49 (07056) 8540  
Toll Free in Germany: 0130 11 21 66  
e-mail: [germany@omega.com](mailto:germany@omega.com)

United Kingdom: 25 Swannington Road, P.O. Box 7, Omega Drive  
Broughton Astley, Leicestershire, Irlam, Manchester,  
LE9 6TU, England M44 5EX, England  
Tel: 44 (1455) 285520 Tel: 44 (161) 777-6611  
Fax: 44 (1455) 283912 Fax: 44 (161) 777-6622  
Toll Free in England: 0800-488-488  
e-mail: [uk@omega.com](mailto:uk@omega.com)



## WARRANTY/DISCLAIMER

OMEGA ENGINEERING, INC. warrants this unit to be free of manufacturing defects for the life of the product.

If the unit should malfunction, it must be returned to the factory for evaluation. OMEGA's Customer Service Department will issue an Authorized Return (AR) number immediately upon phone or written request. Upon examination by OMEGA, if the unit is found to be defective it will be repaired or replaced at no charge. OMEGA's WARRANTY does not apply to defects resulting from any action of the purchaser, including but not limited to mishandling, improper interfacing, operation outside of design limits, improper repair, or unauthorized modification. This WARRANTY is VOID if the unit shows evidence of having been tampered with or shows evidence of being damaged as a result of excessive corrosion; or current, heat, moisture or vibration; improper specification; misapplication; misuse or other operating conditions outside of OMEGA's control. Components which wear are not warranted, including but not limited to contact points, fuses, and triacs.

**OMEGA is pleased to offer suggestions on the use of its various products. However, OMEGA neither assumes responsibility for any omissions or errors nor assumes liability for any damages that result from the use of its products in accordance with information provided by OMEGA, either verbal or written. OMEGA warrants only that the parts manufactured by it will be as specified and free of defects. OMEGA MAKES NO OTHER WARRANTIES OR REPRESENTATIONS OF ANY KIND WHATSOEVER, EXPRESSED OR IMPLIED, EXCEPT THAT OF TITLE, AND ALL IMPLIED WARRANTIES INCLUDING ANY WARRANTY OF MERCHANTABILITY AND FITNESS FOR A PARTICULAR PURPOSE ARE HEREBY DISCLAIMED. LIMITATION OF LIABILITY: The remedies of purchaser set forth herein are exclusive and the total liability of OMEGA with respect to this order, whether based on contract, warranty, negligence, indemnification, strict liability or otherwise, shall not exceed the purchase price of the component upon which liability is based. In no event shall OMEGA be liable for consequential, incidental or special damages.**

CONDITIONS: Equipment sold by OMEGA is not intended to be used, nor shall it be used: (1) as a "Basic Component" under 10 CFR 21 (NRC), used in or with any nuclear installation or activity; or (2) in medical applications or used on humans. Should any Product(s) be used in or with any nuclear installation or activity, medical application, used on humans, or misused in any way, OMEGA assumes no responsibility as set forth in our basic WARRANTY/DISCLAIMER language, and additionally, purchaser will indemnify OMEGA and hold OMEGA harmless from any liability or damage whatsoever arising out of the use of the Product(s) in such a manner.

## RETURN REQUEST/INQUIRIES

Direct all warranty and repair requests/inquiries to the OMEGA Customer Service Department. BEFORE RETURNING ANY PRODUCT(S) TO OMEGA, PURCHASER MUST OBTAIN AN AUTHORIZED RETURN (AR) NUMBER FROM OMEGA'S CUSTOMER SERVICE DEPARTMENT (IN ORDER TO AVOID PROCESSING DELAYS). The assigned AR number should then be marked on the outside of the return package and on any correspondence. The purchaser is responsible for shipping charges, freight, insurance and proper packaging to prevent breakage in transit.

FOR **WARRANTY** RETURNS, please have the following information available BEFORE contacting OMEGA:

1. P.O. number under which the product was PURCHASED,
2. Model and serial number of the product under warranty, and
3. Repair instructions and/or specific problems relative to the product

FOR **NON-WARRANTY** REPAIRS, consult OMEGA for current repair charges. Have the following information available BEFORE contacting OMEGA:

1. P.O. number to cover the COST of the repair,
2. Model and serial number of product, and
3. Repair instructions and/or specific problems relative to the product.

OMEGA's policy is to make running changes, not model changes, whenever an improvement is possible. This affords our customers the latest in technology and engineering.

OMEGA is a registered trademark of OMEGA ENGINEERING, INC.

© Copyright 1996 OMEGA ENGINEERING, INC. All rights reserved. This documentation may not be copied, photocopied, reproduced, translated, or reduced to any electronic medium or machine-readable form, in whole or in part, without prior written consent of OMEGA ENGINEERING, INC.

It is the policy of OMEGA to comply with all worldwide safety and EMC/EMI regulations that apply. OMEGA is constantly pursuing certification of its products to the European New Approach Directives. OMEGA will add the CE mark to every appropriate device upon certification.

The information contained in this document is believed to be correct but OMEGA Engineering, Inc. accepts no liability for any errors it contains, and reserves the right to alter specifications without notice.

**WARNING:** These product are not designed for use in, and should not be used for, patient connected applications.